

IMPACT TROLLEY & ACCESSORIES

Operator Manual

Models: IT-100, ITL-100, ITT-100, & ITTL-100



NOTE TO INSTALLERS

Always Read Instructions Before Use

The Operator Manual contains information relating to the proper use of the Impact Trolley, Impact Trolley accessories and includes all product information. This document may only be removed by the end user. Ensure that this Operator Manual is readily available to operators at all times.

Head Rush Technologies Impact Trolley Operator Manual
P/N 10429-07

Head Rush Technologies products are covered by a number of patents, including U.S. Patents 8,490,751; 8,851,235; 9,016,435 and D654,412 & corresponding patents/applications in the USA and in other countries worldwide.



IMPACT
TROLL

3/4"

TABLE OF CONTENTS

SAFETY INFORMATION	5
WARRANTY CONDITIONS	6
Customer Responsibility	6
CERTIFICATION	8
DESCRIPTION	9
SPECIFICATIONS	10
IMPACT TROLLEY PARTS	11
PRODUCT MARKINGS	13
OPERATING PRINCIPLES	14
How to Use the Impact Trolley	14
IMPACT BRAKING	16
LANYARD SPECIFICATIONS	17
Secondary Lanyard Length	17
ALTERNATE MOUNTING CONFIGURATIONS	19
Incorrect Configurations	22
COMPATIBLE CARABINERS AND CONNECTORS	23
ACCESSORIES & REPLACEMENT PARTS	25
T-Handle Accessory	25
T-Handle Parts	25
T-HANDLE INSPECTION PROCEDURE	26
HOOK ACCESSORY	27
IMPACT SURFACE REPLACEMENT	28
HOOK UPGRADE INSTALLATION	29
COVER PLATE REMOVAL	30
TROLLEY HANDLE REPLACEMENT	31
USER WARNINGS	32
LOADING LIMITS	33
COMPATIBILITY	36
TROLLEY INSPECTION PROCEDURES	37
WORKING CONDITIONS	38
MANUFACTURER DETAILS	39



IMPORTANT SAFETY NOTICE

Zip Lining is a Dangerous Activity

Read Before Installation & Operation

Failure by the installer or operator to heed any and all instructions, warnings, and cautions for the correct installation, operation, care, and maintenance of the Impact Trolley Model IT-100, ITL-100, ITT-100, ITTL-100, and accessories may result in serious injury or death.

The use of this trolley is contingent upon the installation of an engineered zip line system. This product should not be used in impact braking situations unless both a primary and an emergency arrest device (EAD) are present.

The Impact Trolley, all associated accessories, and equipment is designed and specified for use in the recreational zip line industry as a shuttle and pulley. Use of the Impact Trolley for any purposes other than that intended by the manufacturer is not permitted.

Owners and operators of this device are responsible for the safety and supervision of any person using it and are required to assure that proper operation procedures are followed at all times. Owners and operators are encouraged to seek the advice of a qualified professional regarding the instructions in this manual.

These instructions must be made readily available to the operator at all times. All owners and operators must have read and shown to have understood all instructions, labels, markings, and safety information pertaining to the operation, care, and maintenance of the Impact Trolley, its component parts, accessories, and all associated hardware. Failure to do so may result in equipment damage, serious injury, or death.

SAFETY INFORMATION

Symbols Used in this Manual

The following safety symbols are used throughout this manual to highlight potential dangers. One or more precautions may be associated with practices and procedures described within this manual. Failure to adhere to any precautions highlighted can result in death, serious injury, and equipment damage.

Ensure that you read and understand all safety procedures related to the working environment and the task you are undertaking.



DANGER

Indicates a hazardous situation exists that, if not avoided, will result in serious injury or death.



WARNING

Indicates a potentially hazardous situation that, if not avoided, could result in serious injury or death.



CAUTION

Indicates a potentially hazardous situation that, if not avoided, may result in injury or equipment damage.



NOTE

Indicates an action that must be taken to ensure personal safety and prevent damage to property or equipment.



CARE FOR THE ENVIRONMENT

Take care to minimize impact on the environment when carrying out this procedure.

WARRANTY CONDITIONS

The Impact Trolley and associated accessories are warranted against factory defects in materials and workmanship, excluding Specific Field Replaceable Wear Parts (section: Accessories and Replacement Parts), for a period of one (1) year from date of purchase. This warranty applies only to the original purchaser, and is contingent upon the owner/operator using and maintaining the device in accordance with the instructions, including the requirement to maintain regular inspection as described in all applicable manuals.

THIS WARRANTY IS EXPRESSLY IN LIEU OF OTHER WARRANTIES, EXPRESS OR IMPLIED, AND ANY IMPLIED WARRANTY OF MERCHANTABILITY OR FITNESS FOR A PARTICULAR PURPOSE IS HEREBY EXPRESSLY EXCLUDED.

The sole remedy for breach of this warranty, or for any claim in negligence or strict liability in tort, is the repair or replacement of any defective parts at the discretion of the manufacturer. Such parts claimed to be defective shall be returned to Head Rush Technologies, transportation prepaid, for inspection to determine to its satisfaction that said part(s) are defective.

This warranty is null and void if parts other than genuine parts are used, or if any modifications or services have been performed on the device by anyone other than an authorized Head Rush Technologies servicing agent. This warranty does not cover any damages resulting from abuse to the device, damage in transit, or any other damage beyond the control of Head Rush Technologies. Head Rush Technologies makes no warranties in respect to trade accessories or component parts which are not made by Head Rush Technologies. Head Rush Technologies expressly excludes from this warranty the replacement of Specific Field Replaceable Wear Parts, which include the Impact Surface and fasteners, Sheave Assembly, Hook Accessory, Trolley Handles and/or any accessories supplied with this product.

No person, agent, or distributor is authorized to give any warranty, other than the one herein expressed, on behalf of Head Rush Technologies, or to assume for it any liability pertaining to such products. Head Rush Technologies expressly does not warrant merchantability, or claim as to whether the device is suited for a particular purpose. Purchaser agrees that Head Rush Technologies shall not be held liable to purchaser/operator for damages of any kind, including but not limited to, lost or projected profits, equipment down time, or any losses considered to be caused by non-operation or servicing/re-certification down-time of the equipment.

Customer Responsibility

The following items are considered the responsibility of the customer and therefore not covered under the terms of the warranty:

- Routine maintenance, cleaning, and inspection.
- Normal replacement of service and wear items.

-
- Replacements required because of abuse, misuse, or improper operation of equipment by the installer or operator.
 - Wearing parts such as Impact Surface, Sheave Assemblies, Hook Accessory, Trolley Handles and any accessories supplied with this product.
 - Normal deterioration due to use and exposure.
 - Receiving proper training and understanding proper use, limitations, and risk associated with this device.
 - Ensuring all hardware and secondary connectors (carabiners, tethers, etc.) meet all applicable standards.

This warranty is subject to the following of the requirements of the Operator Manual, manufacturer instructions, and advice given by authorized Head Rush Technologies service technicians.

CERTIFICATION

Standards



NOTE

If the Impact Trolley is resold outside of the country of destination, the reseller must provide instructions for use, service, maintenance and repair in the language of the country of use.

The Impact Trolley conforms to Regulation (EU) 2016/425 and comply with the following prevailing Safety regulations:

- **EN 17109:2019** Class E/C/D

EU Declaration of Conformity:

EU Declaration of Conformity can be downloaded at this website address:

<https://headrushtech.com>

Body controlling the manufacture of this PPE:

TÜV SÜD Product Service GmbH

Ridlerstraße 65

80339 München, Germany

Notified body performing the CE type exam:

TÜV SÜD Product Service GmbH

Ridlerstraße 65

80339 München, Germany

The theoretical lifespan of the Impact trolley is 10 years with proper care and maintenance.

DESCRIPTION

The Impact Trolley is a shuttle designed to be used in the recreational zip lining and ropes course industry. The Impact Trolley may only be used on wire rope or cable that meets the necessary strength ratings as stated by ACCT, ASTM, and/or other applicable standards. The maximum operating speed is 120 kph (75 mph) and the suitable rider weight range is 15–150 kg (33–330 lbs).

The Impact Trolley and accessories are designed for durability, ease of use, and portability, and incorporate features specifically designed for use with impact braking systems, specifically the zipSTOP Zip Line Brake. The Impact Trolley may be used with alternative terminal braking systems; however, Head Rush Technologies relinquishes all responsibility regarding the functionality or wear of the trolley with alternative braking systems. Proper testing must always be conducted to ensure compatibility between the Impact Trolley and alternate terminal braking systems. The Impact Surface and approved accessories may be replaced or added as necessary. The Impact Trolley is not suitable for use with textile rope.

The Impact Trolley cannot be used in conjunction with hand braking if a terminal impact brake (ex zipSTOP) is used, except in the case that the design provides for a max weight and speed rider traveling less than 24 kph (15 mph) before impact and is using an Impact Trolley with model numbers IT-100 or ITL-100. Hands and face must be clear of the trolley and impact zone before impact.

To protect the longevity of the Impact Trolley, installation, operation, and care must be in accordance with the instructions in this manual.

NOTE: The Model Number for the standard Impact Trolley is IT-100. Model ITL-100 is the standard Impact Trolley with the Hook Accessory (Model LU-100). Model ITT-100 is the standard Impact Trolley with T-Handle Accessory (Model THS-100). Model ITTL-100 is the standard Impact Trolley with both the Hook Accessory and T-Handle Accessory.

SPECIFICATIONS

MODEL	IT-100	
CLASSIFICATION	Shuttle	
DIMENSIONS	180 x 111 x 33 mm (7.1 x 4.4 x 1.3 in)	
NET WEIGHT	544 grams (1.2 lbs)	
WORKING TEMPERATURE	MINIMUM	-40°C/-40°F
	MAXIMUM	80°C/176°F
MAXIMUM OPERATING SPEED	75 mph (120 kph)	
MATERIALS	HOUSING	Anodized Aluminum
	SHEAVES	Stainless Steel
	IMPACT SURFACE	ABS Plastic
RATED WORKING CAPACITY	15-150 kg (33-330 lbs)	
MIN/MAX. CABLE DIAMETER	9.5 ≤ Dia ≤ 19 mm (3/8" ≤ Dia ≤ 3/4")	

IMPACT TROLLEY PARTS

IT-100

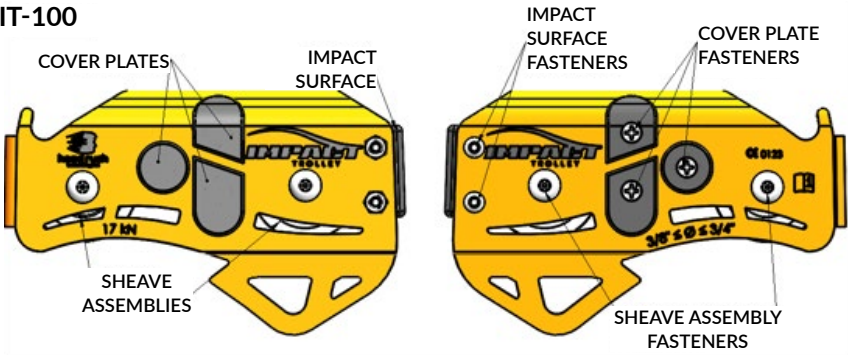

ITL-100

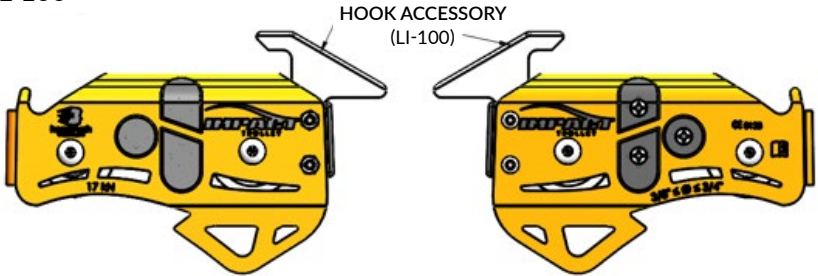

ITT-100

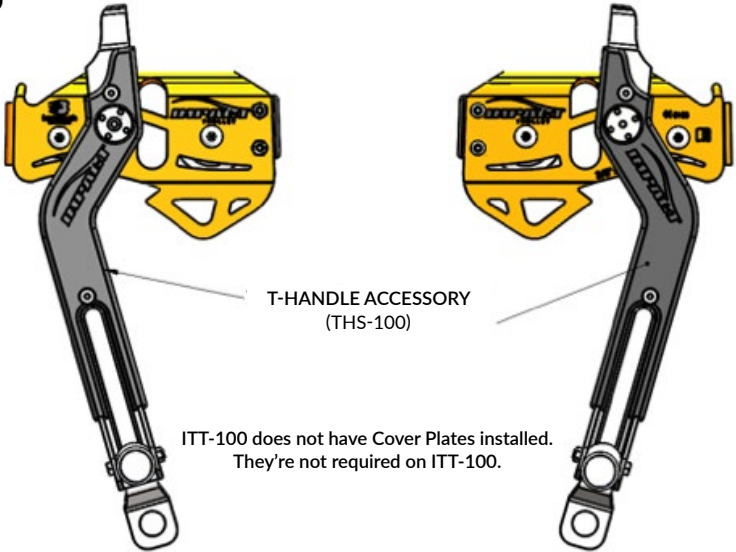

ITTL-100

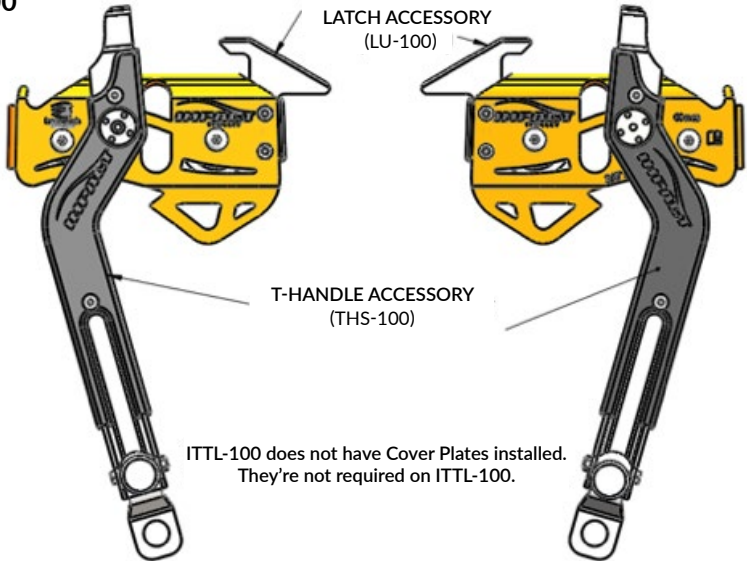

PRODUCT MARKINGS

NAME OF MANUFACTURER: Head Rush Technologies.

MAXIMUM LOAD RATING: 17 kN (3,822 lbf). The Impact Trolley shows the maximum loads as guaranteed by the manufacturer.

MINIMUM & MAXIMUM WIRE ROPE DIAMETER: $3/8" \leq \varnothing \leq 3/4"$. The wire rope/cable diameter that can be used in the Impact Trolley is between 9.5 and 19 mm (between 3/8 and 3/4 of an inch).



REFERENCE TO INSTRUCTIONS

THE "I" REPRESENTS THE REFERENCE TO INSTRUCTIONS LOCATED IN THE IMPACT TROLLEY OPERATOR MANUAL.

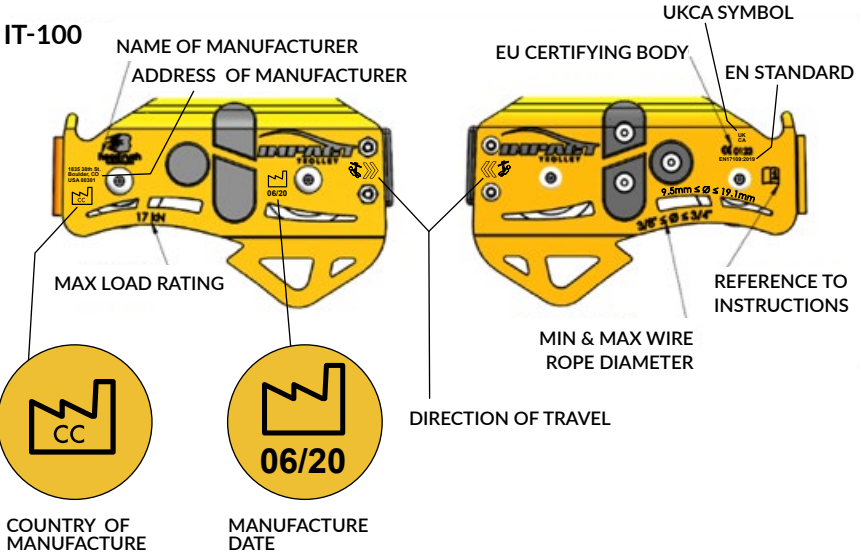

OPERATING PRINCIPLES

How to Use the Impact Trolley

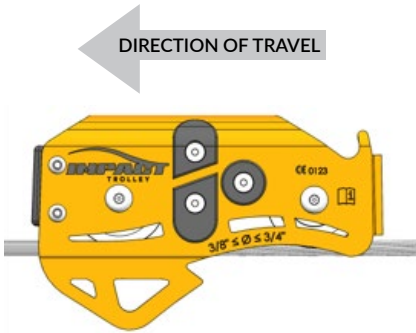

Figure 1: Place the Impact Trolley on the cable. Be sure to orient the trolley such that the front of the trolley (the Impact Surface) faces the direction of travel, as shown above.



ALWAYS USE LOCKING CONNECTING HARDWARE

Always use locking carabiners or other locking connectors rated to 20 kN or greater for both the primary and secondary connection points.



ONLY USE THE IMPACT TROLLEY ON WIRE CABLE

Only use the Impact Trolley on suitable zip line cable. The Impact Trolley must not be used with textile ropes.



DO NOT USE THIS PRODUCT UNLESS BOTH CONNECTION POINTS ARE USED.

Both primary and secondary connection points must be used in all operation.



ONLY LOAD THE PRIMARY CONNECTION POINT

Only load the primary connection point during normal operation. The secondary connection should be loosely tethered to the rider to serve as a back up to the primary.



OPPOSITE AND OPPOSED

Primary and secondary connectors should be installed with locking gates opposite and opposed.



PRIMARY T HANDLE CLIP-IN POINT SHOULD CARRY ALL WEIGHT, WITH MINIMAL ADDITIONAL FORCE APPLIED TO HANDLES.

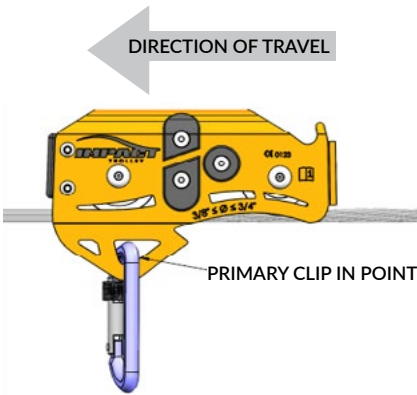

Figure 2: Place the carabiner in the primary clip-in point, as shown above. Clip the carabiner through both holes and ensure that the top of the carabiner does not contact the cable. Always use locking carabiners or connectors.

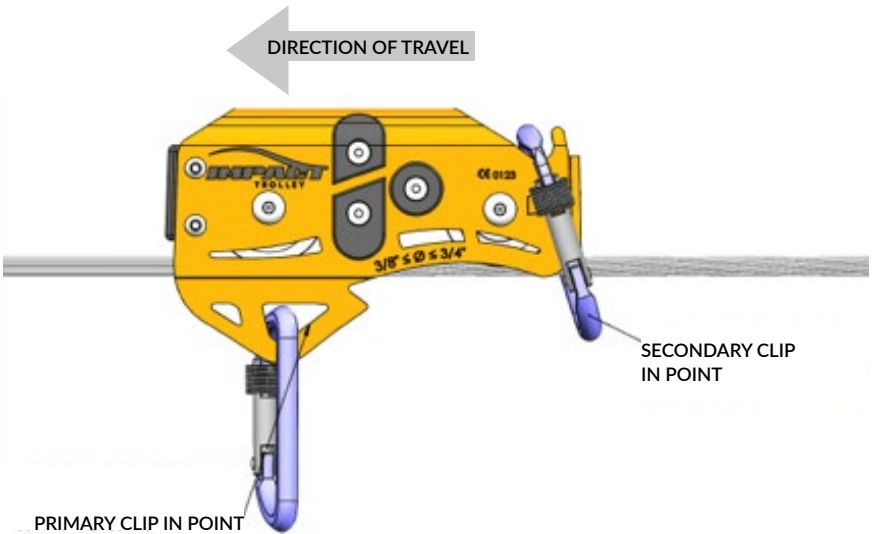

Figure 3: Always use a secondary, back-up carabiner or connector with a loose tether attached to the rider. Ensure that the secondary connector is opposite and opposed to the primary connector, as shown above. Only load the primary connector during normal operation.



CAUTION

The primary clip in point should always be in front of the secondary clip in point.

IMPACT BRAKING

The Impact Trolley is designed to interact with Head Rush Technologies' dynamic braking system: zipSTOP IR, zipSTOP, zipSTOP Brake Trolley and zipSTOP Brake Trolley Catch Accessory. It may be used with other zip line braking systems so long as:

- The zip line has a primary and Emergency Arrest Device (EAD) or Emergency Braking System (EBS). An EAD/EBS are only required if impact or arrival speeds are greater than 11 kph (7 mph).
- The braking surface of the primary brake and EAD/EBS only interacts with the Impact Trolley's Impact Surface (see below image).
- Other surfaces on the Impact Trolley do not interact with the primary and EAD brake (see below image). Brake interaction with other surfaces on the Impact Trolley may result in brake failure, damaged trolley and potential harm to the rider.
- Hands, head and other body parts are kept clear from the Impact Trolley's Impact Surface.
- Impact speeds and max loads do not exceed the primary brake's or EAD's max velocity or load rating.
- The Impact Trolley is designed to interact with the rubber zipSTOP Bumpers. Any other type of brake interface may result in additional wear and may void state warranties.

Braking surface of primary brake and EAD must interact with the Impact Trolley's impact surface.

Impact braking must never occur on the back surface of the Impact Trolley.

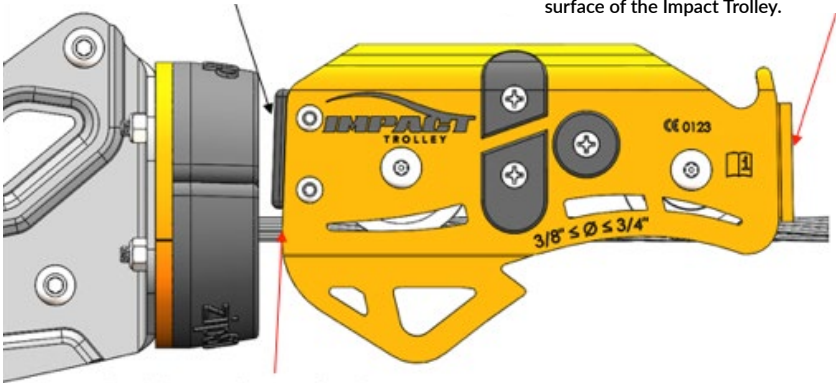

Braking surface of primary brake and EAD must not interact with other surfaces on the Impact Trolley.

LANYARD SPECIFICATIONS

Head Rush Technologies allows the use of any lanyard so long as they meet ACCT, ASTM, and/or any other applicable standards.

If the rider's lanyards originate from the belay loop or comparable location of the rider's harness, the following are recommended minimum lanyard lengths:

- Model IT-100 and ITL-100 is 61 cm (24 in)
- Model ITT-100 and ITTL-100 is 30 cm (12 in)

Note: Lanyard lengths do not include carabiners/connectors.

Always Verify proper lanyard length through testing. Lanyards should be long enough to prevent head, face, or hand impacts in worst case scenario conditions. Proper lanyard lengths are the responsibility of the installer and/or operator. Head Rush Technologies accepts NO responsibility for improper configuration or use of the impact trolley and/or lanyard used with the impact trolley.



ONLY USE CERTIFIED LANYARDS

Primary and secondary lanyards must meet ACCT, ASTM, and/or any other applicable standard.



ENSURE RIDERS HEAD IS BELOW THE ZIP LINE

During operation, ensure the riders head is at least 30 cm (12 inches) below the zip line and zip line trolley.



DO NOT USE SHORTER LANYARDS

Shorter lanyards may result in rider's hands and/or face colliding with the trolley during impact braking. Always verify that the lanyard connection is long enough to prevent head, face, or hand impact during impact braking in the worst case conditions. Lanyard lengths are only a guideline and must be verified by the operator and builder.

Secondary Lanyard Length

A secondary, back-up connector should always be used. This secondary lanyard should be slack during standard use and during impact braking while the primary lanyard remains weighted.

During impact braking, a rider generally swings forward and up. This swing increases the distance between the harness attachment point and the secondary clip in point on the Impact Trolley. If the secondary lanyard is too short, the secondary clip in point will be weighted during impact braking and cause excess wear on the trolley and line.

CORRECT

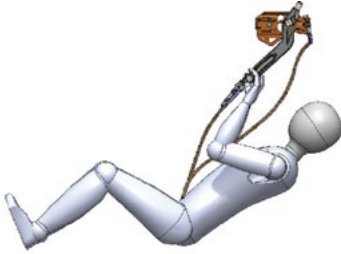

INCORRECT

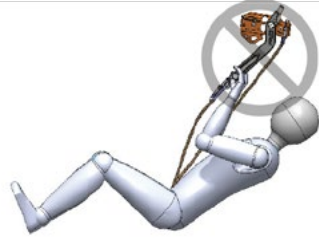

CAUTION

Ensure that the secondary tether and attachment point are of sufficient length to prevent loading or binding during braking and handle swing. Binding or loading to the back of the trolley during braking will increase wear on the trolley dramatically. Improper loading produces forces that the Impact Trolley has not been designed for.

ALTERNATE MOUNTING CONFIGURATIONS

The Impact Trolley can be mounted in several approved alternative configurations to accommodate a variety of zip line operations. Head Rush Technologies only approves the configurations shown below.



USE CORRECT COVER PLATE CONFIGURATION

Do not remove or tamper with cover plates unless it is required by the Impact Trolley configuration chosen. Always use the correct configuration of cover plates to prevent appendages, loose items, foreign objects, etc. from becoming lodged in the Impact Trolley during use.

IT-100

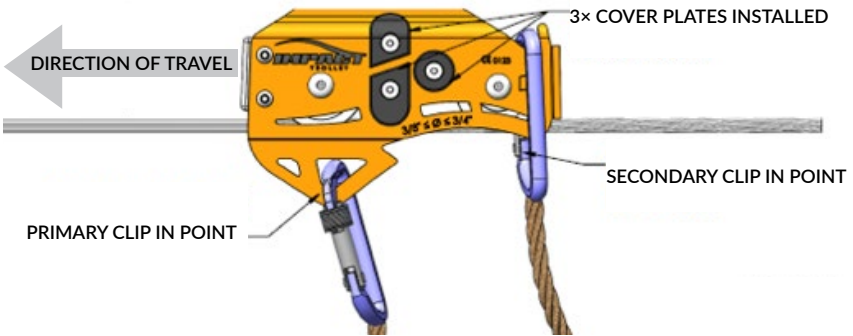

Configuration 1
(Recommended for IT-100 and ITL-100 for single line zip line)

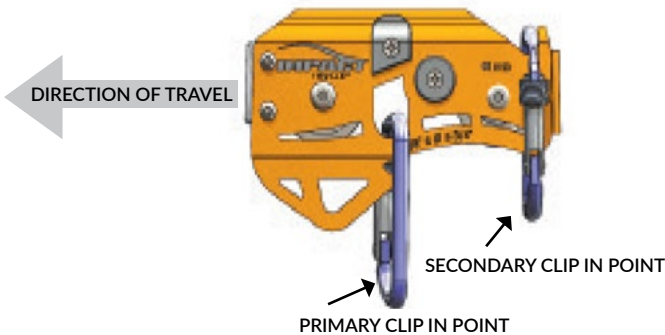

Configuration 2
(Recommended for IT-100 and ITL-100 for single line zip line)

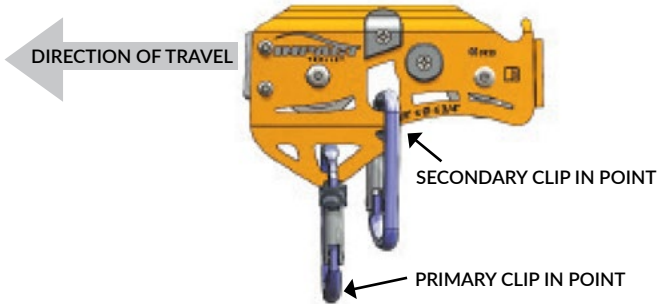

*Configuration 3
(Recommended for IT-100 and ITL-100 for single line zip line)*

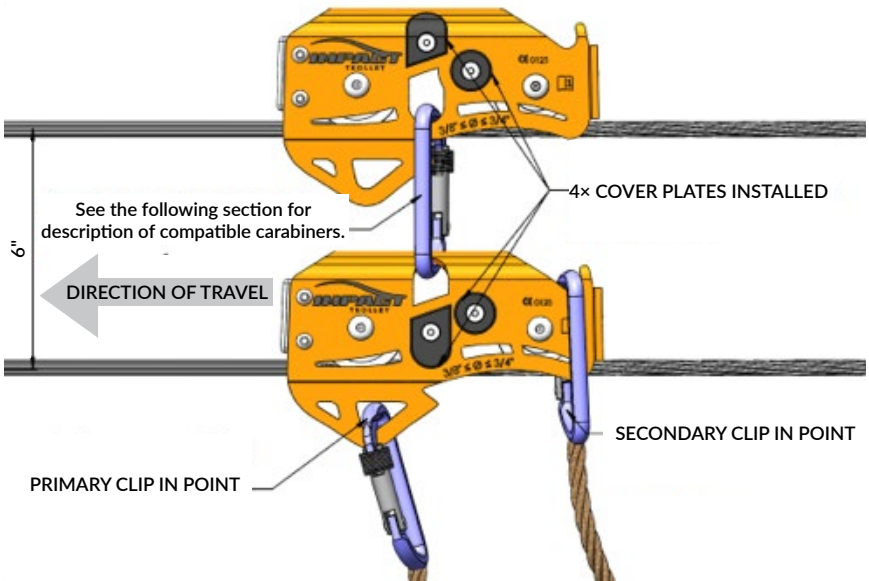

*Configuration 4
(Recommended for IT-100 and ITL-100 for dual line zip line)*

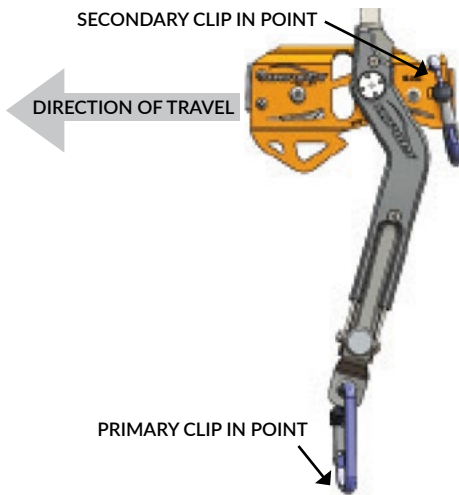

Configuration 5
 (Recommended for IT-100 and ITL-100 for single line zip line)



CAUTION

The secondary clip in point must be behind the T Handle. Incorrect configuration of the clip in points with the T Handle may cause cracking and failure of the product.

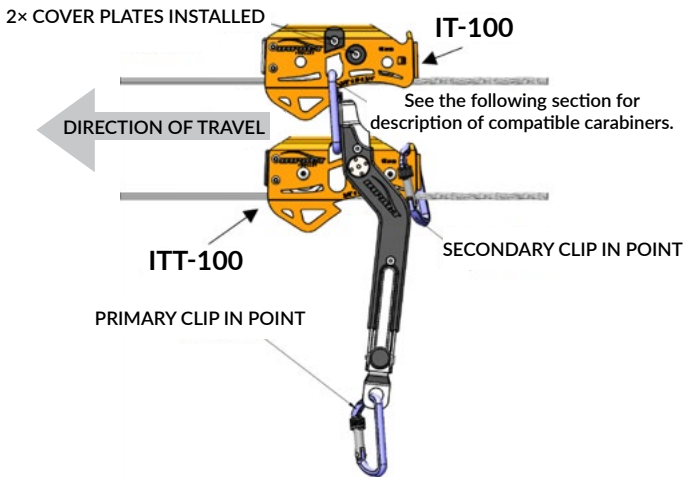

Configuration 6
 (Recommended for ITT-100 and ITTL-100 on dual line zip lines)

Incorrect Configurations

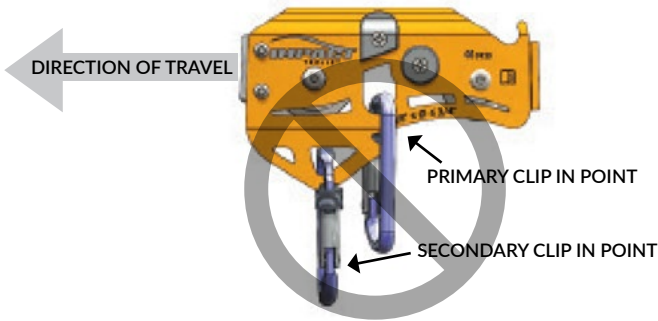

Incorrect Configuration 1



CAUTION

If the secondary clip-in point is in front of the primary, it may inhibit the riders swinging motion during impact braking. This may cause the attachment points to interfere with each other and create unnecessary wear to the Impact Trolley.

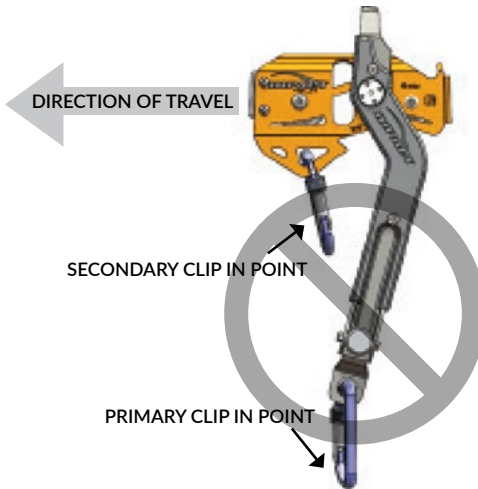

Incorrect Configuration 2



CAUTION

If the secondary clip-in point is in front of the T Handle, it may inhibit the pivoting range of the T Handle. Thus causing the T Handle to stop abruptly during impact braking, creating a large impact force on the T Handle clip in point

COMPATIBLE CARABINERS AND CONNECTORS

Only compatible carabiners and/or connectors may be used in order to ensure proper operation and longevity of the Impact Trolley. Using incompatible carabiners or connectors may cause accelerated wear of the clip-in points or carabiner, contact or wear with the zip line, or augmented braking. A carabiner or connector is compatible if it meets the following criteria:

- **STRENGTH:** 20 kN (4,496 lbf) minimum
- **Metallic Locking connectors only. Plastic, textile, lanyards, etc. are NOT allowed. Aluminum alloy carabiners of sufficient rating and strength are best since harder metals may cause accelerated wear to clip-in points.**
- It is normal and expected for aluminum carabiners and the primary clip in point to seat together during initial usage of this product. This will manifest or appear as slight wear or deformation in both aluminum parts until the mating surfaces have sufficient bearing area.
- **FORM:** The connector must pass through both clip-in points such that the trolley cannot be removed from the zip line without removing the connector. The connector must not be able to contact the zip line.
- **ORIENTATION:** Only use connectors that, when loaded, keep the Impact Trolley upright with the load centered under the zip line. D-shaped, pear-shaped, or comparable connectors may not be compatible.
- **SIZE:** When the Impact Trolley is used in tandem, the connector provides the necessary line distance of 152 mm (6 in) (see Mounting Configurations 2 and 4).
- **MOVEMENT:** The connector does not bind, catch, or inhibit the T-Handle Accessory from pivoting in the direction of travel.



DANGER

Attach only carabiners or comparable, metallic connectors rated to at least 20kN (4,496 lbf). Never use lanyards or other textiles directly connected to the trolley or zip cable.



ALWAYS USE LOCKING CONNECTING HARDWARE

Always use locking carabiners or other locking connectors for both the primary and secondary connection points to ensure the participant cannot accidentally become detached during use.



DO NOT REMOVE COVER PLATES

Cover plates may only be removed if a compatible carabiner or connector is used through the hole that the cover plate was removed from.



ONLY USE COMPATIBLE CARABINERS AND/OR CONNECTORS

Use only compatible connectors in order to ensure proper operation and longevity of the Impact Trolley.

ACCESSORIES & REPLACEMENT PARTS

T-Handle Accessory



MODEL	THS-100	
CLASSIFICATION	Pivoting Swing Arm	
DIMENSIONS (FOLDED)	360 x 30 x 50 mm (14.2 x 1.2 x 2.0 in)	
NET WEIGHT	1.1 kg (2.4 lbs)	
WORKING TEMPERATURE	MINIMUM	-40°C/-40°F
	MAXIMUM	80°C/176°F
MATERIALS	Stainless Steel	
RATED WORKING CAPACITY	15–150 kg (30–330 lbs)	

The Impact Trolley T-Handle is designed as an accessory to the Impact Trolley. The T-Handle is only compatible with the Impact Trolley and is not compatible with any other shuttle, pulley, or device used for a similar purpose. The T-Handle Accessory is not a Field Replaceable Wear Component and must be purchased in conjunction with the Impact Trolley. The Trolley Handles (see the diagram on page 21) are replaceable in the field by the end user. The maximum designed impact velocity is 80 kph (50 mph) and max impact force is 3.5 kN (786 lbf).

T-Handle Parts

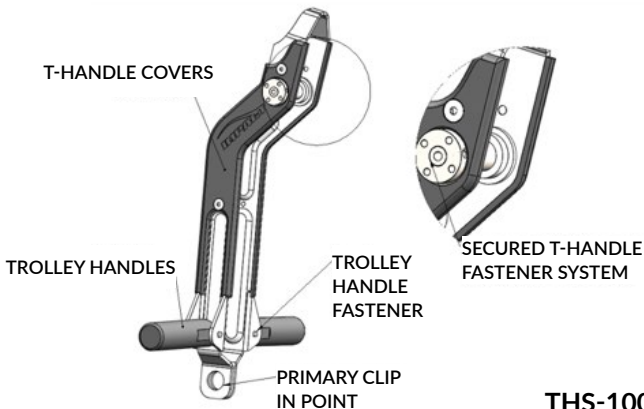

THS-100

T-HANDLE INSPECTION PROCEDURE

- Before each use, ensure that the T Handle Accessory rotates freely and does not bind on the connectors, tethers, or any other part of the Impact Trolley.
- Verify that the T Handle Fastener System is tight and secure.
- If one or both of the Trolley Handles sit at an angle greater than 100° to the T Handle (as shown below), it is recommended that the Trolley Handles be replaced.

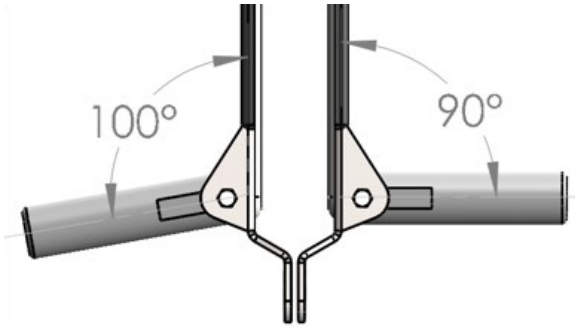

- To prolong the life of the Trolley Handles, ensure that the primary T Handle clip-in point carries all rider weight, with minimal additional force applied to handles.

HOOK ACCESSORY



MODEL	LU-100	
DIMENSIONS	71 x 81 x 6 mm (2.8 x 3.2 x 0.24 in)	
NET WEIGHT	0.2 lbs (3.2 oz)	
WORKING TEMPERATURE	MINIMUM	-40°C/-40°F
	MAXIMUM	80°C/176°F
MATERIALS	Stainless Steel	

The Hook Accessory is designed for the Impact Trolley and works in conjunction with the Brake Catch Accessory. The Hook Accessory is only compatible with the Impact Trolley and Brake Catch Accessory and is not compatible with any other shuttle, pulley, or device used for a similar purpose. The Hook Accessory is designed to keep both assemblies attached after impact braking, making for easier rider retrieval. The Hook Accessory may be used on any Head Rush Technologies approved Mounting Configuration (see Alternate Mounting Configurations). See the zipSTOP Zip Line Brake Operator Manual (Revision 2.1 or Newer) or Brake Trolley Catch Accessory Supplement for further information regarding the Brake Trolley Catch Accessory.

IMPACT SURFACE REPLACEMENT

The Impact Surface, Model Number IS-100, is a Field Replaceable Wear Component which may be replaced by the end user. For maximum life and best performance, use the Impact Trolley in conjunction with the zipSTOP Brake Trolley.

REQUIRED TOOLS

- 1/8" Hex Key
- 3/8" Wrench

SUPPLIED HARDWARE (INCLUDED WITH REPLACEMENT IMPACT SURFACE)

- 1 × Impact Surface
- 2 × 10-32 Top Lock Nuts
- 2 × #10 Washer
- 2 × 1.5" 10-32 Button Head Cap Screw

HOW TO REPLACE THE IMPACT SURFACE

1. Using the 1/8" hex key and 3/8" wrench, loosen and remove the two Top Lock Nuts from the Button Head Cap Screw. The Button Head Cap Screw will then be free to come off the Impact Trolley assembly. Discard used Top Lock Nuts.
2. Once the Button Head Cap Screws are removed, slide the Impact Surface away from the assembly and replace with the new Impact Surface. Ensure the new Impact Surface is oriented correctly and does not contact the front sheave.
3. Tighten the new Top Lock Nuts, #10 Washers, and Button Head Cap Screw to the Impact Trolley.



DO NOT REUSE TOP LOCK NUTS

New top lock nuts must be used each time they are removed from the assembly.

HOOK UPGRADE INSTALLATION

The Hook Accessory, Model Number LU-100, may be added to an Impact Trolley at any time. It is field replaceable and may be installed by the end user. The Hook Accessory is designed to work only with the Impact Trolley and Brake Trolley Catch Accessory.

REQUIRED TOOLS

- 1/8" Hex Key
- 3/8" Wrench

SUPPLIED HARDWARE (INCLUDED WITH REPLACEMENT IMPACT SURFACE)

- 1 × Hook Accessory
- 2 × 10-32 Top Lock Nuts
- 2 × #10 Washer
- 2 × 1.5" 10-32 Button Head Cap Screw

HOW TO REPLACE THE IMPACT SURFACE

1. Using the 1/8" hex key and 3/8" wrench, loosen and remove the two Top Lock Nuts from the Button Head Cap Screw. The Button Head Cap Screw will then be free to come off the Impact Trolley assembly. Discard used Top Lock Nuts.
2. Once the Button Head Cap Screws are removed, slide the Impact Surface away from the assembly.
3. Insert the Hook Accessory into the slit in the Impact Surface. To check for the correct orientation, ensure the Hook Accessory and Impact Surface outer edges are flush.
4. Insert the Impact Surface with the Hook Accessory back into the Impact Trolley. Ensure the Impact Surface is oriented correctly and does not contact the front sheave.
5. Tighten the new Top Lock Nuts, #10 Washers, and Button Head Cap Screw to the Impact Trolley.



DO NOT REUSE TOP LOCK NUTS

New top lock nuts must be used each time they are removed from the assembly.

COVER PLATE REMOVAL

The Cover Plates are installed to prevent any appendages, loose items, or foreign objects from entering the Impact Trolley at any point.

Certain configurations require Cover Plates to be removed from the assembly (see Mounting Configurations 1–3 on pages 18–19).

REMOVAL INSTRUCTIONS

1. Use a Phillips Head screwdriver to unscrew the fastening bolt.
2. Once the bolt is removed, pull each Cover Plate from the Impact Trolley.
3. Keep Cover Plates and bolt for future replacement.



USE CORRECT COVER PLATE CONFIGURATION

Do not remove or tamper with the Cover Plates unless it is required by the Impact Trolley mounting configuration chosen. Always use the correct configuration of Cover Plates to prevent appendages, loose items, foreign objects, etc. from becoming lodged or caught in the Impact Trolley during use.



ENSURE COVER PLATES ARE INSTALLED

Cover plates must be installed and in place unless the opening is being utilized with a compatible carabiner or connector.

TROLLEY HANDLE REPLACEMENT

The Trolley Handles, Model Number TH-100, are Field Replaceable Wear Components which may be replaced by the end user. For maximum life and best performance, ensure riders are not holding their body weight via the Trolley Handles.

REQUIRED TOOLS

- 2 × 8 mm Wrench

SUPPLIED HARDWARE (INCLUDED WITH THE TROLLEY HANDLE REPLACEMENT)

- 2 × Trolley Handle
- 2 × Trolley Handle Fastener
- 2 × Trolley Handle Nylock
- 4 × Spring Washer

HOW TO REPLACE THE TROLLEY HANDLES

1. Using both 8 mm wrenches, loosen and remove the Trolley Handle Nylocks from the Trolley Handle Fastener. The Trolley Handle Fastener will then be free to come off the Impact Trolley T-Handle assembly. Discard the used Trolley Handle Nylocks.
2. Once the Trolley Handle Fasteners are removed, slide the Trolley Handles away from the assembly.
3. Place the new Spring Washers in the indents on the new Trolley Handles. Slide the Trolley Handle back into the tabs on the T-Handle. A dab of grease or other viscous material may be necessary to retain the Spring Washers in the indent.
4. Put the new Trolley Handle Fasteners through the T-Handle Assembly and tighten the new Trolley Handle Nylocks.
5. Ensure that the Trolley Handles rotate smoothly and when engaged sit at a 90° angle from the T-Handle assembly.



DO NOT REUSE TROLLEY HANDLE NYLOCK

New Trolley Handle Nylon locking nuts must be used each time they are removed from the assembly.

USER WARNINGS



Do not modify the Impact Trolley. Only use authentic Head Rush Technologies accessories.



Do not exceed impact speeds greater than 80 kph (50 mph) or impact force greater than 3.5 kN (786 lbf).



When the Impact Trolley is used in conjunction with zipSTOP or zipSTOP IR Zip Line Brake, all installation guidelines must be met according to the zipSTOP or zipSTOP IR manual.



The Impact Trolley may only be used in accordance with all local and state regulations.



User must ensure the braking system is not restricted and is fully functional.



In installations where impact or arrival velocities are in excess of 11 kph (7 mph), both a primary and emergency brake system are required.



If impact speeds exceed 24 kph (15 mph) hand braking is prohibited with Impact Trolley IT-100 and ITL-100.



For Impact Trolley ITT-100 and ITTL-100 hand braking is prohibited.



During impact braking, ensure all body parts, including hands and head are clear from the trolley and impact area.



Always ensure the trolley sits upright on the wire rope or cable and is in the correct forward orientation.



Do not exceed 120 kph (75 mph).



Ensure the trolley does not dangle from the harness when not in use. Always secure the trolley to the side of rider harnesses or hold the trolley when it's not in use.

LOADING LIMITS

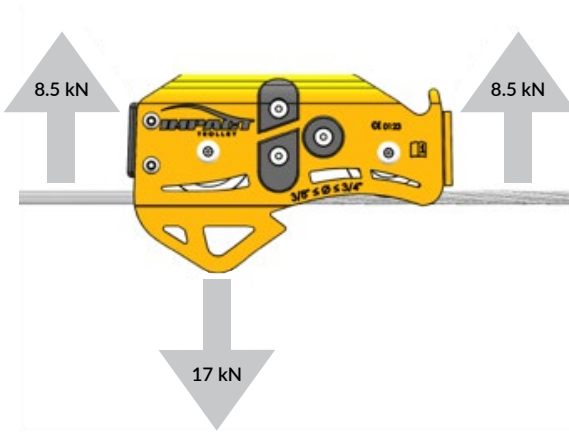

BREAKING LIMIT LOAD

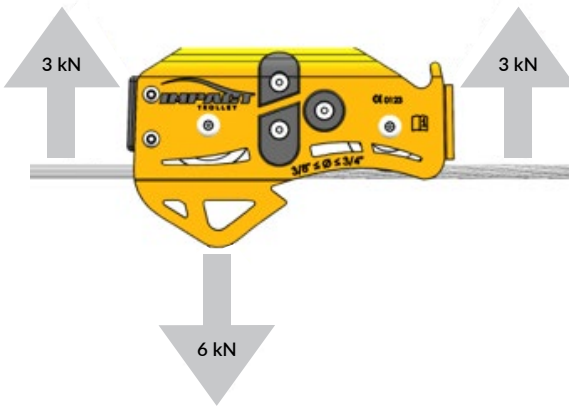

WORKING LOAD LIMIT

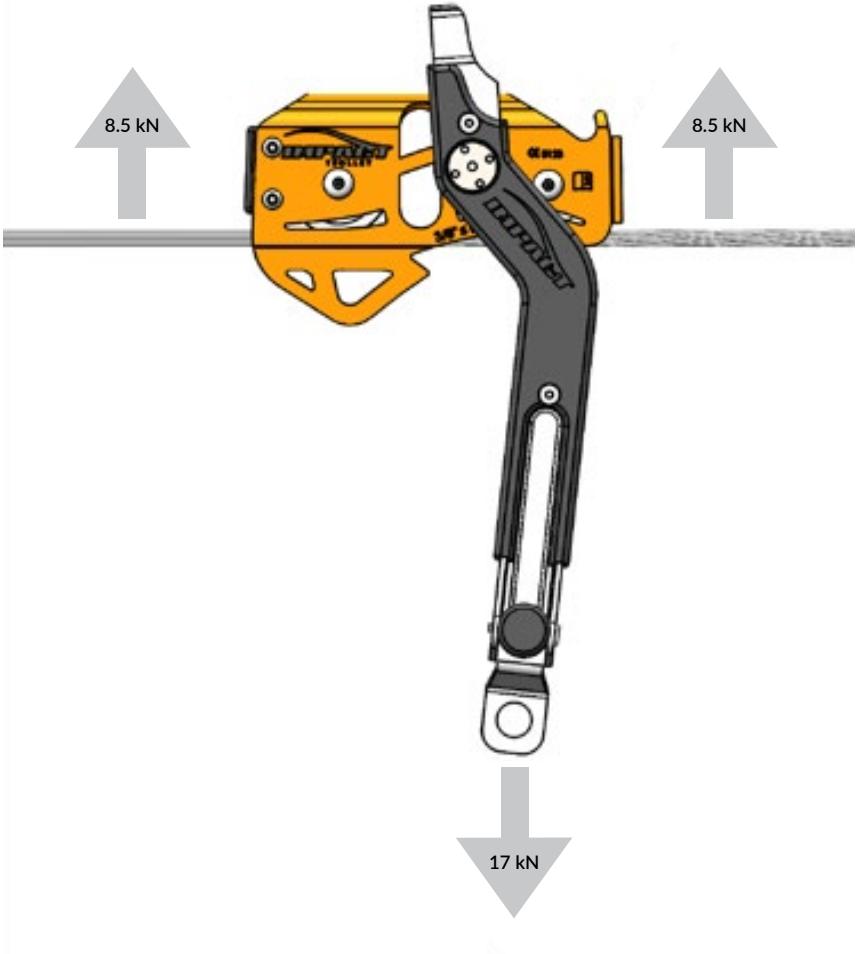

BREAKING LIMIT LOAD

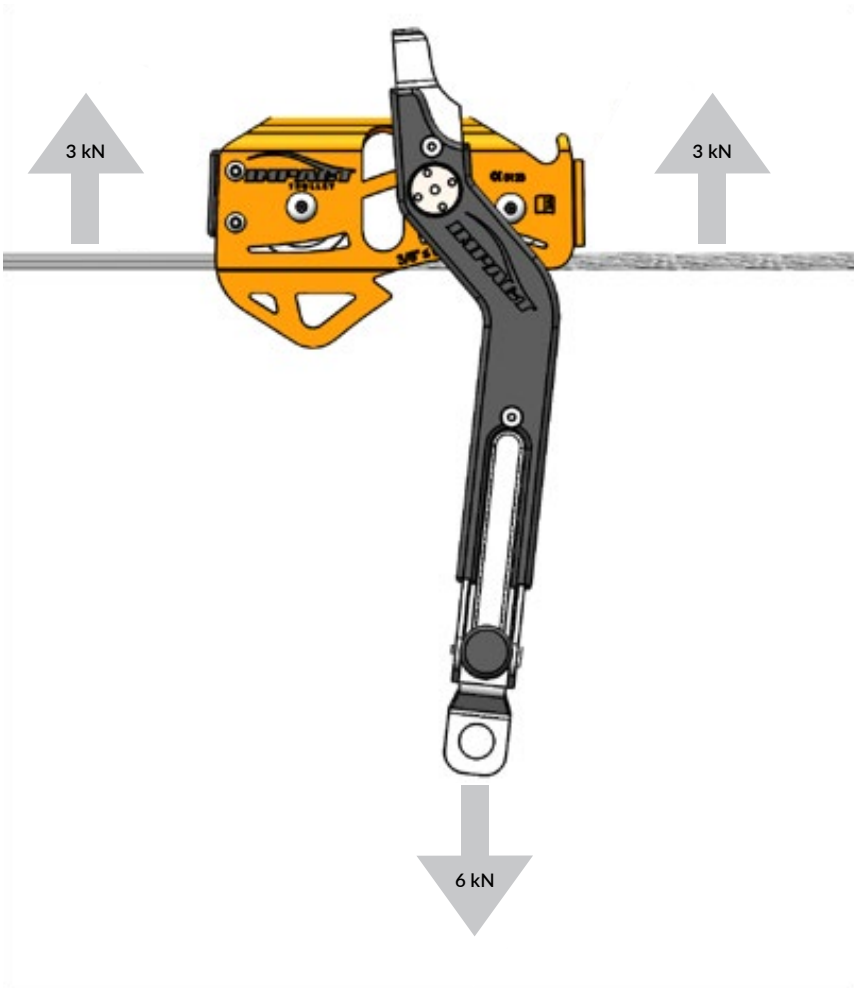

WORKING LOAD LIMIT

COMPATIBILITY

- Verify that the zip line cable used is between 9.5 and 19 mm (between 3/8" and 3/4"), inclusive.
- Use only compatible connectors in conjunction with the Impact Trolley.
- Make sure other connectors, hardware, etc. used (other than carabiners) are not in contact with the trolley.
- Equipment used with the trolley (cable, carabiners, lanyards, etc.) must meet all applicable standards.
- All Impact Trolley Accessories are designed to work only with the Impact Trolley.

TROLLEY INSPECTION PROCEDURES

BEFORE EACH USE

- Check and verify that there is no damage to the Impact Trolley and accessories, such as cracks, corrosion, deformation, etc.
- Check and verify that the Impact Trolley sheaves rotate freely without any contact or abnormal rubbing.
- Check and verify all fasteners are securely tightened and there are no loose components.

DURING EACH USE

- Ensure that the trolley is properly oriented such that the cable does not rub on the side plates, connectors, or other components.
- Ensure that the connectors are properly attached, locked, and secure.
- If a dynamic brake system is used, ensure it is fully functional.

SERVICE SCHEDULE

In addition to the prior stated inspections, Head Rush Technologies recommends an in-depth inspection at least every month of product use. High-use facilities and operations in harsh or saline environments should perform this inspection at least weekly. This inspection must be performed by a competent inspector. Depending on conditions and intensity of use, inspections may need to occur more frequently. If any damage is found or there are any concerns regarding proper operation, immediately discontinue use of the Impact Trolley and contact an Authorized Head Rush Technologies Service Center.



Do not use the Impact Trolley if there are signs of damage including cracking, corrosion, deformation, or if the trolley does not perform as indicated.

WORKING CONDITIONS

WORKING TEMPERATURE	MINIMUM	-40°C/-40°F
	MAXIMUM	80°C/176°F

STORAGE Store the Impact Trolley in a dry area where it is protected from UV light, chemicals, or any other extreme conditions.

CLEANING The only cleaning supplies that should be used are mild household soap or detergent and water. Compressed air may be used to blow out dirt and debris.

DRYING Do not dry the Impact Trolley in direct UV light or near a heat source. Use a clean cloth or let the Impact Trolley air-dry.

MAINTENANCE Do not apply oil, grease, solvents, etc. Modifications/repairs not specifically approved by Head Rush Technologies are prohibited. Field replaceable components may be replaced in accordance to individual component instructions.

MANUFACTURER DETAILS

Return the Impact Trolley to the manufacturer at the address shown below for any service or repairs.

ADDRESS

Head Rush Technologies
1699 Cherry St, Suite C
Louisville, CO 80027
USA

CONTACT DETAILS

+1-720-565-6885
www.headrushtech.com
info@headrushtech.com

EU importers may apply their name and address on the device to comply with government regulations next to the specification label.



IMPACT
TROLLEY

66123

3/8

IMPACT



www.headrushtech.com

info@headrushtech.com

+1-720-565-6885

Apr 2023